

BAS RTP-B

Portable BACnet/IP to MS/TP Router

Installation Guide

TD070210-01B

Trademarks

Contemporary Controls, ARC Control, ARC DETECT, EXTEND-A-BUS, RapidRing, and CTRLink are trademarks or registered trademarks of Contemporary Control Systems, Inc. Specifications are subject to change without notice. Other product names may be trademarks or registered trademarks of their respective companies. BACnet is a registered trademark of the American Society of Heating, Refrigeration, and Air-Conditioning Engineers, Inc. (ASHRAE).

TD070210-0IB 19 November 2008

Copyright

© Copyright 2008 by Contemporary Control Systems, Inc. All rights reserved. No part of this publication may be reproduced, transmitted, transcribed, stored in a retrieval system, or translated into any language or computer language, in any form or by any means, electronic, mechanical, magnetic, optical, chemical, manual, or otherwise, without the prior written permission of:

Contemporary Control Systems, Inc.
2431 Curtiss Street
Downers Grove, Illinois 60515 USA
Tel: 1-630-963-7070
Fax: 1-630-963-0109
E-mail: info@ccontrols.com
Web: www.ccontrols.com

Contemporary Controls (Suzhou) Co. Ltd
11 Huojia Road, Science & Technology Park
New District, Suzhou, PR China 215009
Tel: +86-512-68095866
Fax: +86-512-68093760
E-mail: info@ccontrols.com.cn
Web: www.ccontrols.asia

Contemporary Controls Ltd
Sovereign Court Two, UWSP
Sir William Lyons Road
Coventry CV4 7EZ UK
Tel: +44 (0)24 7641 3786
Fax: +44 (0)24 7641 3923
E-mail: info@ccontrols.co.uk

Contemporary Controls GmbH
Fuggerstraße 1, 04158
Leipzig Germany
Tel: +49-0341-520359-0
Fax: +49-0341-520359-16
E-mail: info@ccontrols.de
Web: www.ccontrols.eu

Disclaimer

Contemporary Control Systems, Inc. reserves the right to make changes in the specifications of the product described within this manual at any time without notice and without obligation of Contemporary Control Systems, Inc. to notify any person of such revision or change.

Contents

1	Introduction	4
2	Specifications	5
	Electrical.....	5
	Environmental	5
	Functional.....	5
	Electromagnetic Compatibility.....	6
	Connectors.....	6
	Mechanical	7
3	Power.....	7
4	Operation	9
	MS/TP Port.....	9
	Ethernet Port.....	9
	IP Address Reset Switch	9
	LEDS	9
5	Webpage Configuration	10
	Device Parameter	13
	BACnet/IP Parameters	13
	MS/TP Parameters.....	14
6	Warranty.....	15
7	Declaration of Conformity	16

1 Introduction

The BASRTP-B routes messages between BACnet/IP and BACnet MS/TP networks as per the ANSI/ASHRAE 135-2004 standard. It allows BACnet/IP devices to communicate with MS/TP devices. The unit is configurable via its internal webpage.

The unit attaches to a USB port of your computer and has one isolated MS/TP port and one 10/100 Mbps Ethernet Auto-MDIX port.

The MS/TP port offers a 3-pin terminal block with a removable plug for the EIA-485 connection. Through this port, up to 254 devices can be addressed — as many as 31 on the local bus. All MS/TP baud rates are supported.

The Ethernet port offers a shielded RJ-45 connector. Through auto-negotiation and Auto-MDIX, it automatically matches its duplex setting, data rate and signal polarity to whatever is needed by the attached equipment. Thus, only a straight-through CAT5 cable is needed for hook-up.

The USB port is strictly used to power the BASRTP-B. No communications is supported via the USB port.

The BASRTP-B features a user-accessible switch to reset the IP address, subnet mask and gateway address to the factory defaults.

Three LEDs are present: A power LED glows green when proper power is provided. The Ethernet LED glows green for 100 Mbps operation and yellow for 10 Mbps and flashes to indicate activity. A green LED flashes when MS/TP traffic is received.

Each unit complies with Class A radiated and conducted emissions as defined by EN55022 and CFR 47, Part 15, and is intended for use in non-residential areas.

2 Specifications

Electrical

INPUT	USB (Type B Port)
Voltage (V, nominal):	5 VDC
Current (mA, typical):	300
Power:	2.5 W

Environmental

Operating temperature:	0°C to 60°C
Storage temperature:	-40°C to +85°C
Relative humidity:	10–95%, non-condensing

Functional

	Ethernet	<i>MS/TP</i>
Signaling:	10BASE-T	<i>EIA-485</i>
	100BASE-TX	<i>(ANSI/ASHRAE 135-2004)</i>
Cable length limit:	100 m	<i>1200 m (for AWG 18)</i>
MS/TP Baud rate (bps):	9600, 19200, 38400, 76800	
MS/TP node limit:	254 devices total, 31 devices per segment	
MS/TP LED:	flashing green = receive valid activity	
Ethernet LED:	green = 100 Mbps	
	yellow = 10 Mbps	
	flashing = activity	

Regulatory Compliance

CE Mark; RoHS; CFR47, Part 15 Class A

Electromagnetic Compatibility

Each unit complies with Class A radiated and conducted emissions as defined by EN55022 and CFR 47, Part 15. This equipment is intended for use in non-residential areas.

Warning

This is a Class A product as defined in EN55022. In a domestic environment this product may cause radio interference in which case the user may be required to take adequate measures.

Connectors

3-pin (MS/TP) Pin Assignments

(Also explained on product label)

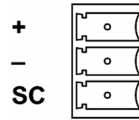

Figure 1 — 3-pin Connector

RJ-11 (MS/TP) Pin Assignments

- 2 RT –
- 4 SC
- 5 RT +

(All other pins are unused.)

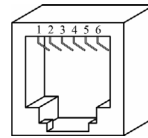

Figure 2 — RJ-11 Connector

RJ-45 (MDI Ethernet) Pin Assignments

- 1 TD + 3 RD +
- 2 TD – 6 RD –

(All other pins are unused.)

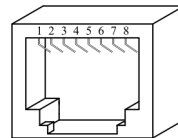

Figure 3 — RJ-45 Connector

Mechanical

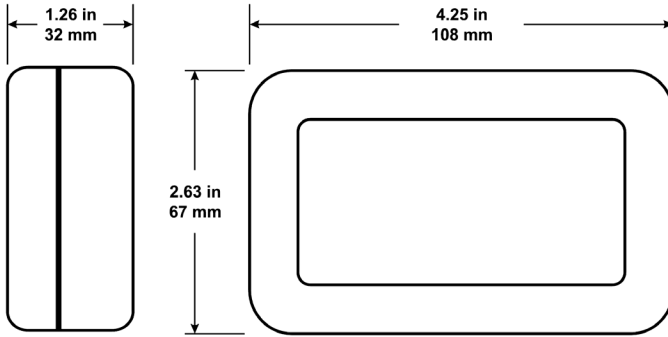

Figure 4 — Product Dimensions

3 Power

The BASRTP-B features a USB 2.0 Full Speed Device Port that accepts the USB cable with Type B plug that is included in the box. It takes 5 VDC from a host computer, while typically drawing 300 mA of current. It can operate from a USB hub, if desired, and no driver installation is needed.

For MS/TP devices, see Figure 5 for proper 2-wire bus connections and Figure 6 for proper 3-wire bus connections. The BASRTP-B does not apply any failsafe bias or termination.

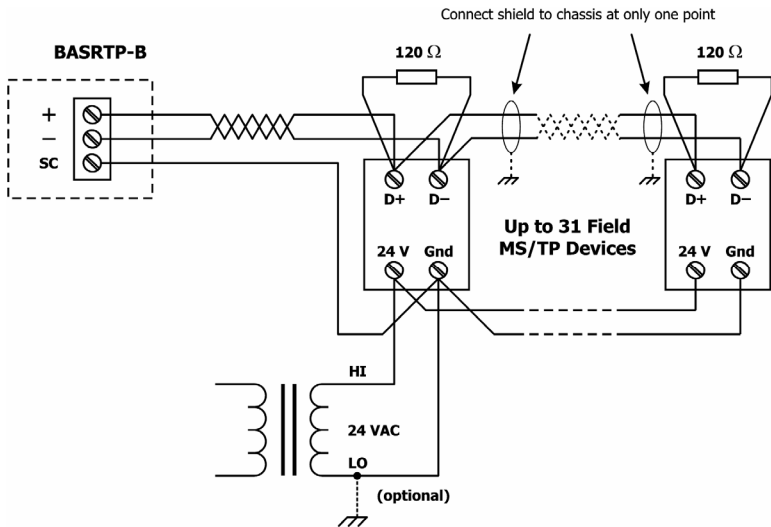

Figure 5 — 2-wire MS/TP Bus Wiring

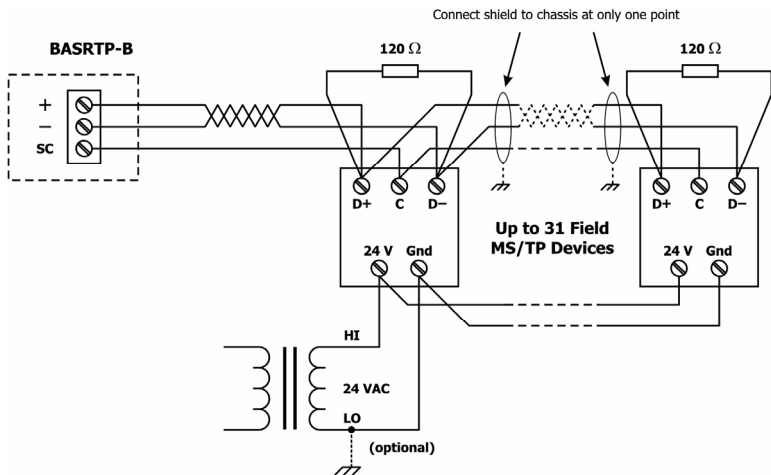

Figure 6 — 3-wire MS/TP Bus Wiring

4 Operation

MS/TP Port

The MS/TP port uses an isolated EIA-485 transceiver that is connected to both a removable 3-pin connector (*Figure 1*) and an RJ-11 jack. Either connector can be used for the MS/TP line. The EIA-485 transceiver's + and – lines tie to + and – pins of both connectors. The SC pin ties to the circuit ground of the EIA-485 transceiver and is isolated from both the USB and Ethernet ports.

The router can access 254 MS/TP devices and supports 31 devices on the local bus at rates of 9600, 19200, 38400, or 76800 bps.

Ethernet Port

This port offers a shielded RJ-45 connector. Through auto-negotiation and Auto-MDIX, it automatically matches its duplex setting, flow control, data rate and signal polarity to whatever is needed by the attached equipment. Thus, the provided CAT5 cable is the only cable needed for the Ethernet hook-up.

IP Address Reset Switch

When pressed for at least 1 second (at any time the router is under power), this switch will reset the default values of the IP address (192.168.92.68), gateway address (192.168.92.1) and netmask (24).

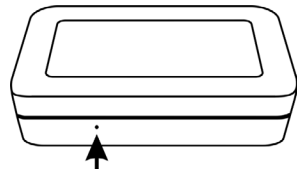

Figure 7 — Reset Switch

It is accessed by a paper clip (or similar device) via a small hole in the case — then after reboot, the default values apply.

LEDS

- Power* glows green if power supplied to the unit is proper
- Ethernet* glows solid for a valid link (green for 100 Mbps or yellow for 10 Mbps) and flashes to show activity
- MS/TP* flashes green when receiving valid MS/TP traffic

5 Webpage Configuration

Each router contains an interactive web server, accessible from any Internet-compatible PC on the local network and compatible with recent versions of Internet Explorer (5.0 or later, suggested) or Netscape Navigator (7.1 or later, required). It is factory-programmed with a default IP address of 192.168.92.68 and a Class C subnet mask of 255.255.255.0 (/24).

Figure 8 shows the setup for accessing the MS/TP network using the BASRTP-B, a computer for configuration, and a connection to the MS/TP network. Make sure that a USB cable connects between the PC and the BASRTP-B so it can be powered.

To configure the router, attach it to a computer with an Ethernet connection and a standard web browser. For initial configuration, the PC chosen for the procedure should temporarily have its IP address modified as illustrated in *Figure 9* — which employs a Windows[®] XP example.

The example in *Figure 9* suggests an IP address for the PC of 192.168.92.69, but the final quad of the address could be any value from 3 to 254 — except for 68 which is used by the router. After the IP address of the PC has been set to the same subnet as the router, a browser can access the router via its default IP address.



Figure 8 — Setup for Initial IP Address Configuration

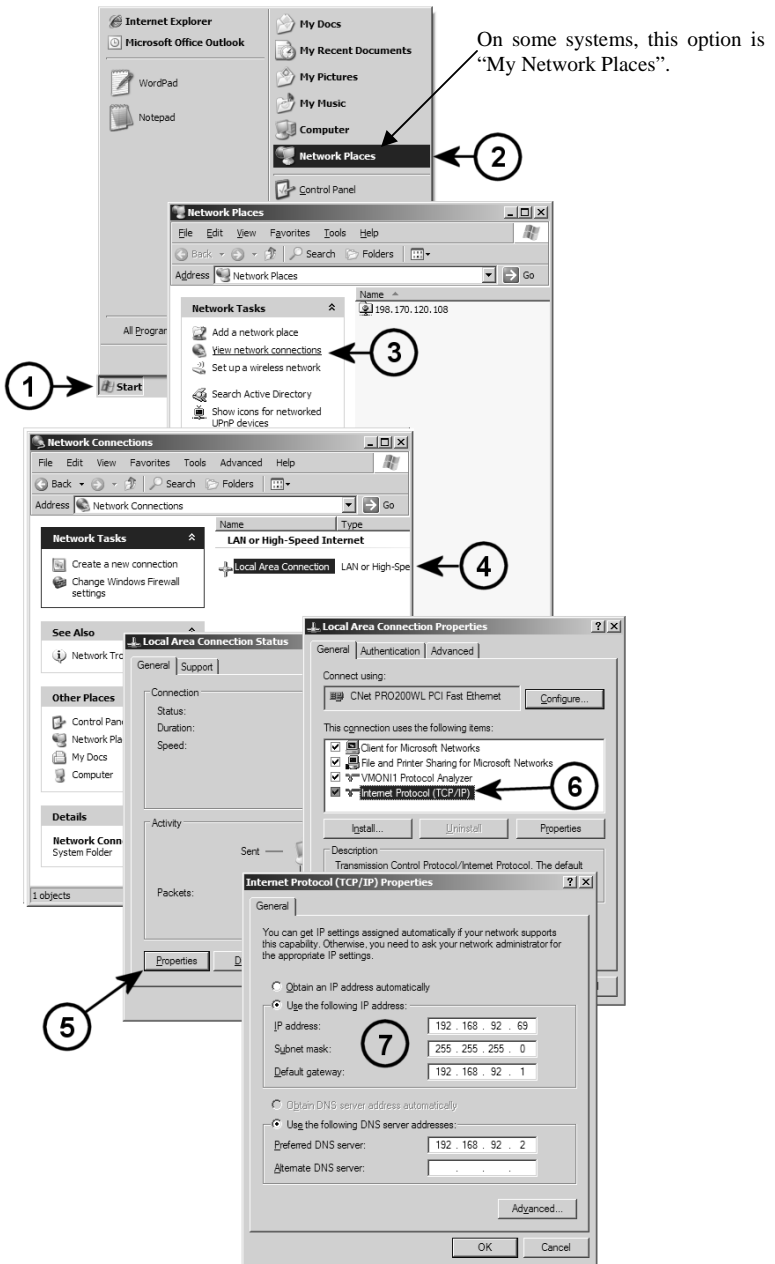

Figure 9 — Steps for Changing the IP Address of the PC Used for Setup

After entering the router's IP address into your browser's address field, you will see the Router Configuration Page with the default values as shown in *Figure 10* — using Windows Internet Explorer.

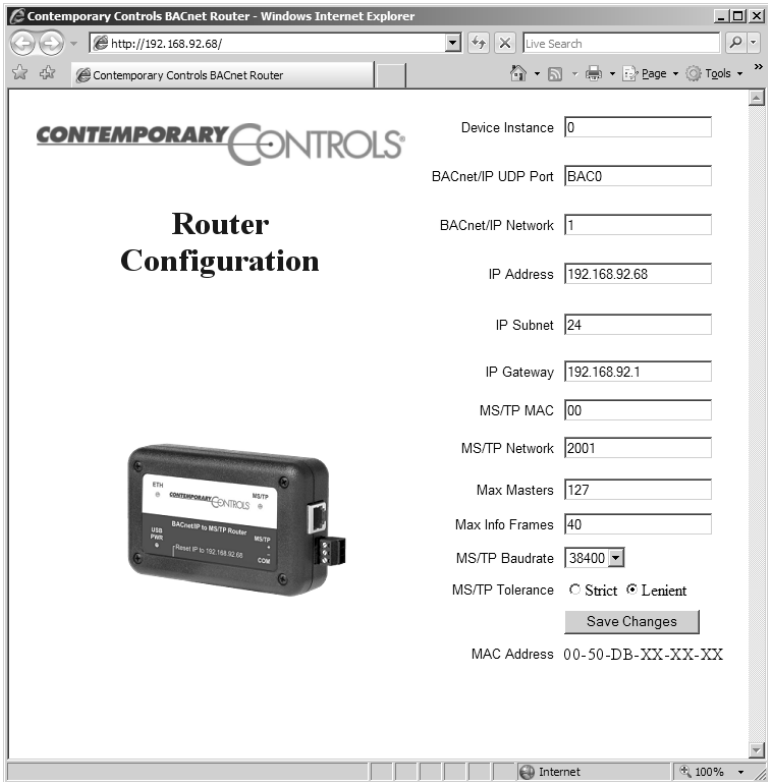

Figure 10 — Router Configuration Page with Default Values

Each parameter of the configuration is explained on the following pages. When *save changes* is selected, the parameters are stored to non-volatile memory and you are prompted to recycle power to the unit. Until power is removed and then restored, your changes **will not apply**.

Device Parameter

Device Instance (Default Value = 0)

The router's device instance is a 22-bit value (0–4,194,303). Each network device must have a unique device instance.

BACnet/IP Parameters

BACnet/IP UDP Port (Default Value = 0xBAC0)

This 16-bit hex value (BAC0–BACF) is set to BAC0 by default. Usually, this value should not be changed.

BACnet/IP Network (Default Value = 1)

The BACnet/IP network number is a 16-bit value (1–65535). Each network must have a unique number.

IP Address (Default Value = 192.168.92.68)

The IP address of the router can be 0.0.0.1–255.255.255.254.

IP Subnet (Default Value = 24)

This value (0–30 in the “slash” notation) is the number of *bits* with a “1” in the mask. The default value of 24 corresponds to 255.255.255.0 in the dotted *decimal* format. All devices on the same subnet which communicate via BACnet/IP should use the same subnet mask.

IP Gateway (Default Value = 192.168.92.1)

The default gateway for the IP stack is a dotted decimal number in the range of 0.0.0.0–255.255.255.254.

MS/TP Parameters

MS/TP MAC (Default Value = 00)

This is the 8-bit (0–127) MAC address of the router’s MS/TP port, in decimal. Lower MAC address numbers are preferred.

MS/TP Network (Default Value = 2001)

This 16-bit decimal network number (1–65535) must be unique. No other MS/TP network can have the same network number.

Max Masters (Default Value = 127)

The highest master MAC address (in decimal) in the MS/TP network can be as large as 127 and you should use 127 if you are unsure of other MS/TP device addresses. Each MS/TP device should use this same value. For a value in this field to be proper, it must equal or exceed the highest MAC address for any master on the network. Optimum performance occurs when this value:

1. ***equals*** the highest MAC address of any master, and
2. all masters use ***sequential*** MAC addresses

Max Info Frames (Default Value = 40)

This is the maximum number of messages that can be routed onto the MS/TP network by the router per token pass. Its range is 1–40, and typical values are 20–40. Smaller values provide less access to the MS/TP network from the BACnet/IP network because they give native MS/TP messages higher priority than those passed by the router from BACnet/IP.

MS/TP Baud rate (Default Value = 9600)

The baud rate of the MS/TP network can be 9600, 19200, 38400 or 76800 bps. All MS/TP devices on the same MS/TP network must use the same baud rate.

MS/TP Tolerance (Default Selection = Lenient)

This setting determines the degree to which interoperability with devices is successful. The Lenient option is less efficient for traffic flow but optimizes interoperability.

6 Warranty

Contemporary Controls (CC) warrants this product to the original purchaser for two years from the product shipping date. Product returned to CC for repair is warranted for one year from the date the repaired product is shipped back to the purchaser or for the remainder of the original warranty period, whichever is longer.

If **the** product fails to operate in compliance with its specification during the warranty period, CC will, at its option, repair or replace the product at no charge. The customer is, however, responsible for shipping the product; CC assumes no responsibility for the product until it is received.

CC's limited warranty covers products only as delivered and does not cover repair of products that have been damaged by abuse, accident, disaster, misuse, or incorrect installation. User modification may void the warranty if the product is damaged by the modification, in which case this warranty does not cover repair or replacement.

This warranty in no way warrants suitability of the product for any specific application. IN NO EVENT WILL CC BE LIABLE FOR ANY DAMAGES INCLUDING LOST PROFITS, LOST SAVINGS, OR OTHER INCIDENTAL OR CONSEQUENTIAL DAMAGES ARISING OUT OF THE USE OR INABILITY TO USE THE PRODUCT EVEN IF CC HAS BEEN ADVISED OF THE POSSIBILITY OF SUCH DAMAGES, OR FOR ANY CLAIM BY ANY PARTY OTHER THAN THE PURCHASER.

THE ABOVE WARRANTY IS IN LIEU OF ANY AND ALL OTHER WARRANTIES, EXPRESSED OR IMPLIED OR STATUTORY, INCLUDING THE WARRANTIES OF MERCHANTABILITY, FITNESS FOR PARTICULAR PURPOSE OR USE, TITLE AND NONINFRINGEMENT.

Returning Products for Repair

Before returning a product for repair, contact Customer Service. A representative will instruct you about our return procedure.

Contemporary Control Systems, Inc.
2431 Curtiss Street
Downers Grove, Illinois 60515 USA
Tel: +1-630-963-7070
Fax: +1-630-963-0109
E-mail: info@ccontrols.com
WWW: <http://www.ccontrols.com>

Contemporary Controls Ltd
Sovereign Court Two, UWSP
Sir William Lyons Road
Coventry CV4 7EZ UK
Tel: +44 (0)24 7641 3786
Fax: +44 (0)24 7641 3923
E-mail: info@ccontrols.co.uk

7 Declaration of Conformity

Applied Council Directives:

Electromagnetic Compatibility Directive, 2004/108/EEC Council Directive

General Product Safety Directive 92/59/EEC

Standards to which Conformity is Declared

EN 55022:1998/A2:2003 CISPR 22:1997/A2:2002, Class A, Limits and Methods of Measurement of Radio Disturbance Characteristics of Information Technology Equipment

EN 55024:1998/A2:2003 CISPR 24:1997/A2:2002., Information Technology Equipment — Immunity Characteristics — Limits and Methods of Measurement

Manufacturer:

Contemporary Control Systems, Inc.
2431 Curtiss Street
Downers Grove, IL 60515 USA

Authorized Representative:

Contemporary Controls Ltd
Sovereign Court Two, UWSP
Sir William Lyons Road
Coventry CV4 7EZ UK

Type of Equipment:

BACnet/IP to MS/TP router

Model:

BAS RTP-B

I, the undersigned, hereby declare that the products specified above conform to the listed directives and standards.

George M. Thomas, President

April, 2008

TD070210-0IB